

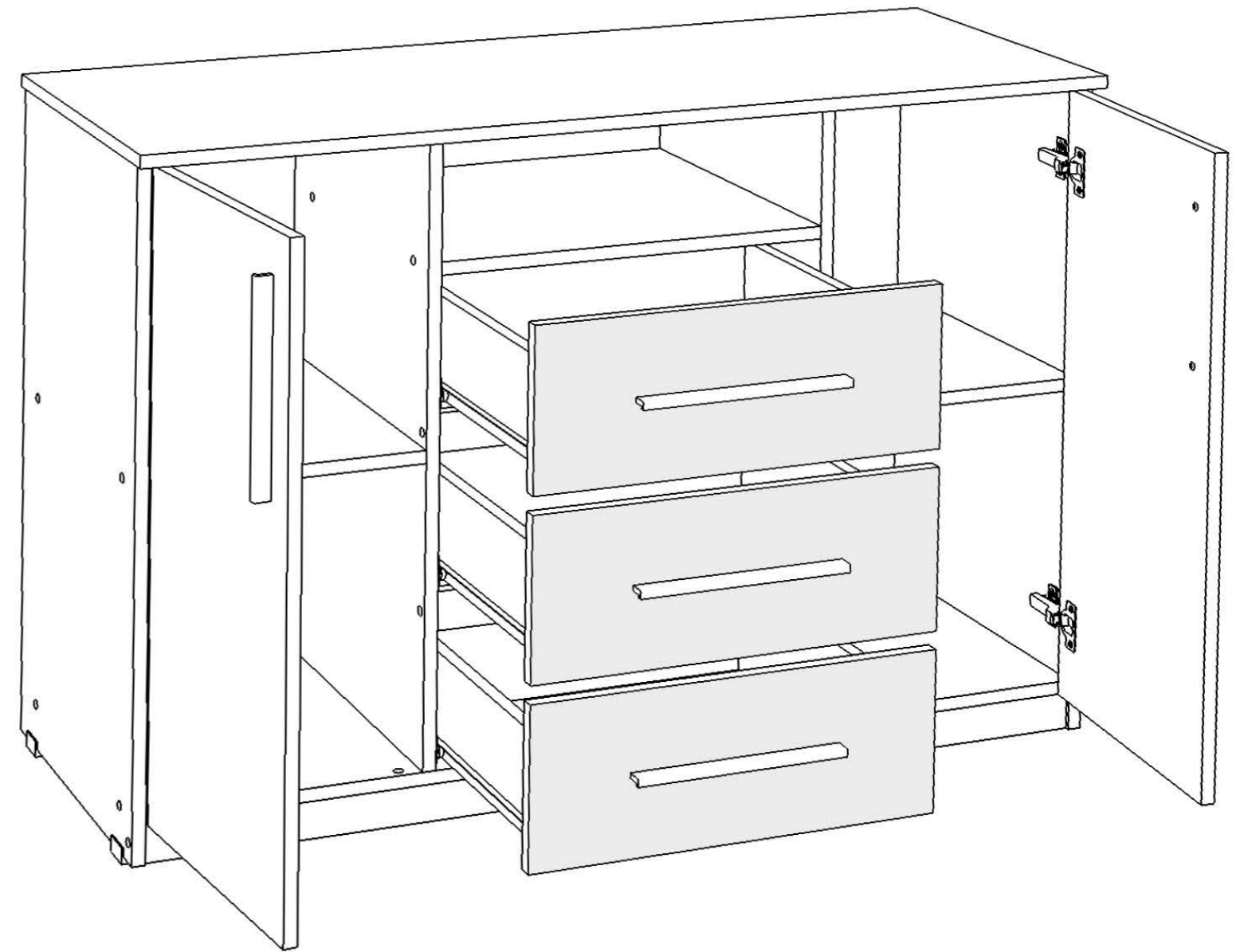

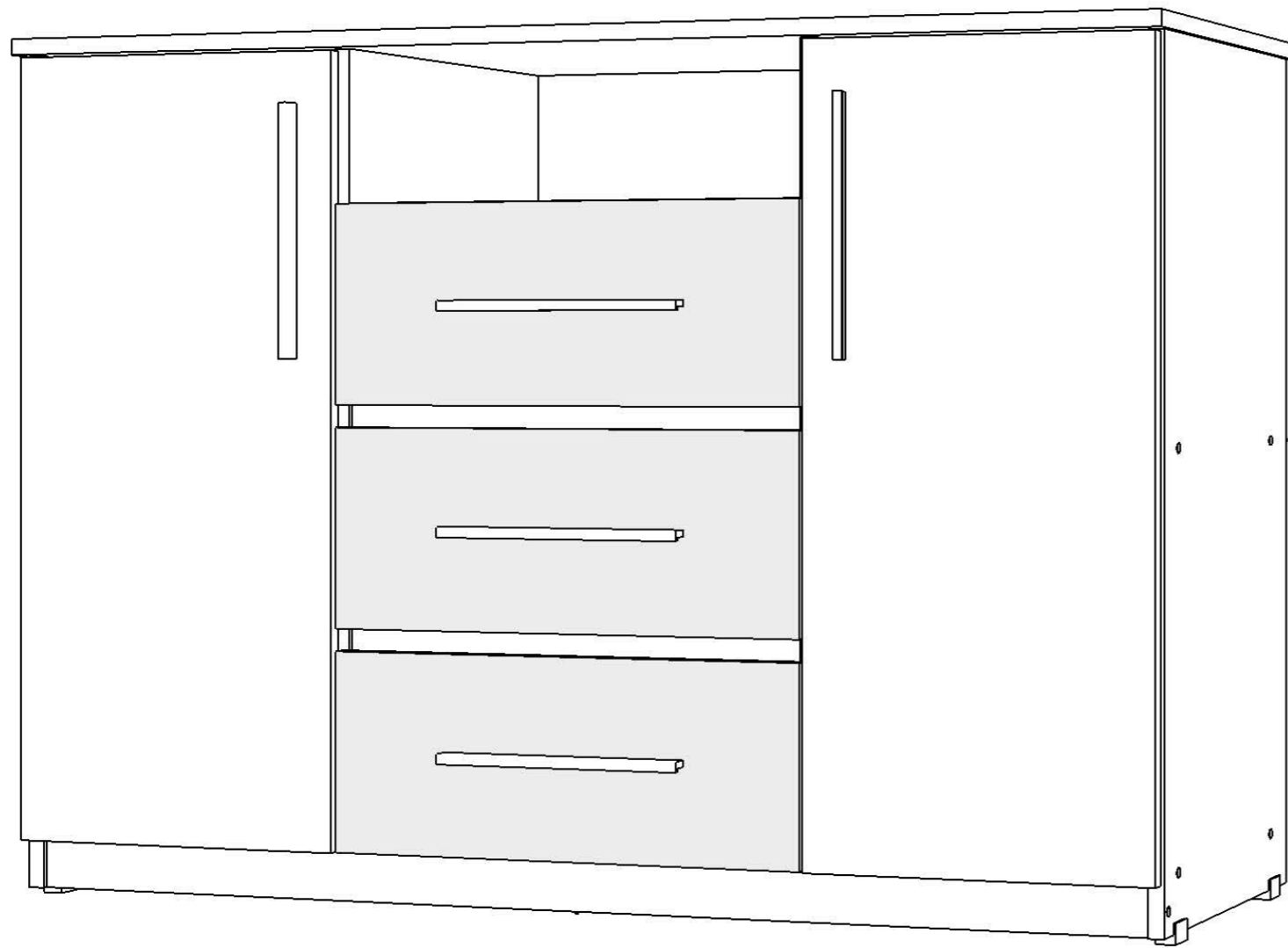

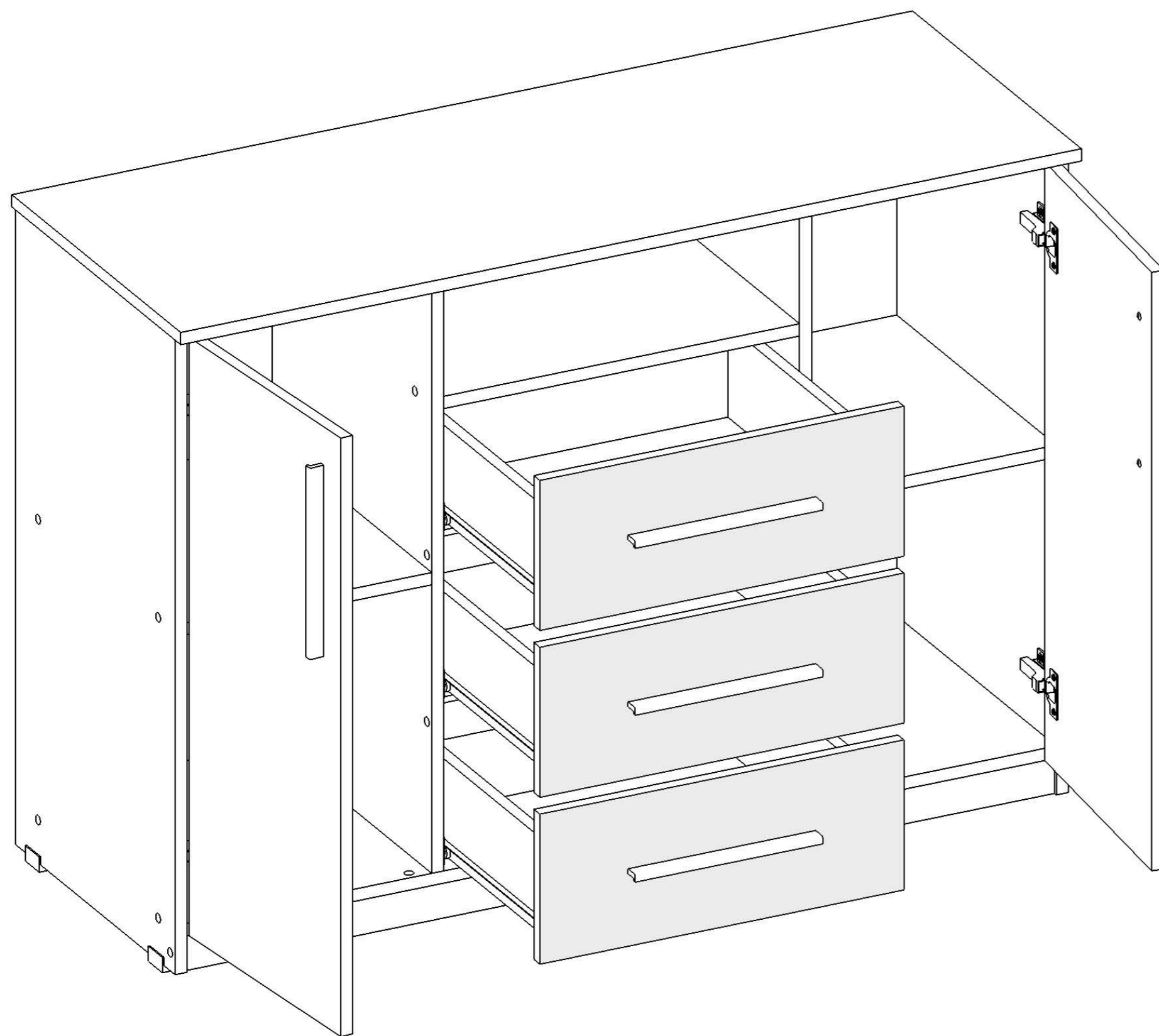

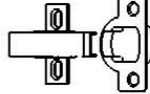



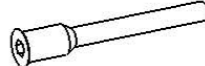
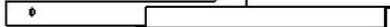

**COMODA Maya**

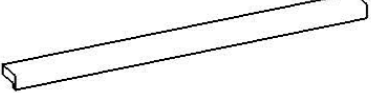

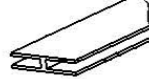
## COMODA Maya - ACCESORII



DENUMIRE	POZA	NB
Aracet ( gr. )		50
Balama Aplicata		4
Capac Mascare Ericson		44
Cep Lemn 8x35		36
Cheie Imbus		1
Ericson 7x50		52
Glisiera 400 ( set-uri )		3
Holzsurub 3.5x16		28
Holzsurub 3.5x30		26
Maner 192mm		5
Picior H=10mm ( Alunecator )		4
Profil pt. PFL ( L=474mm )		1
Surub M4x20		4
Surub M4x 40		6
Tinte		100

# COMODA Maya - SCHITA MONTAJ

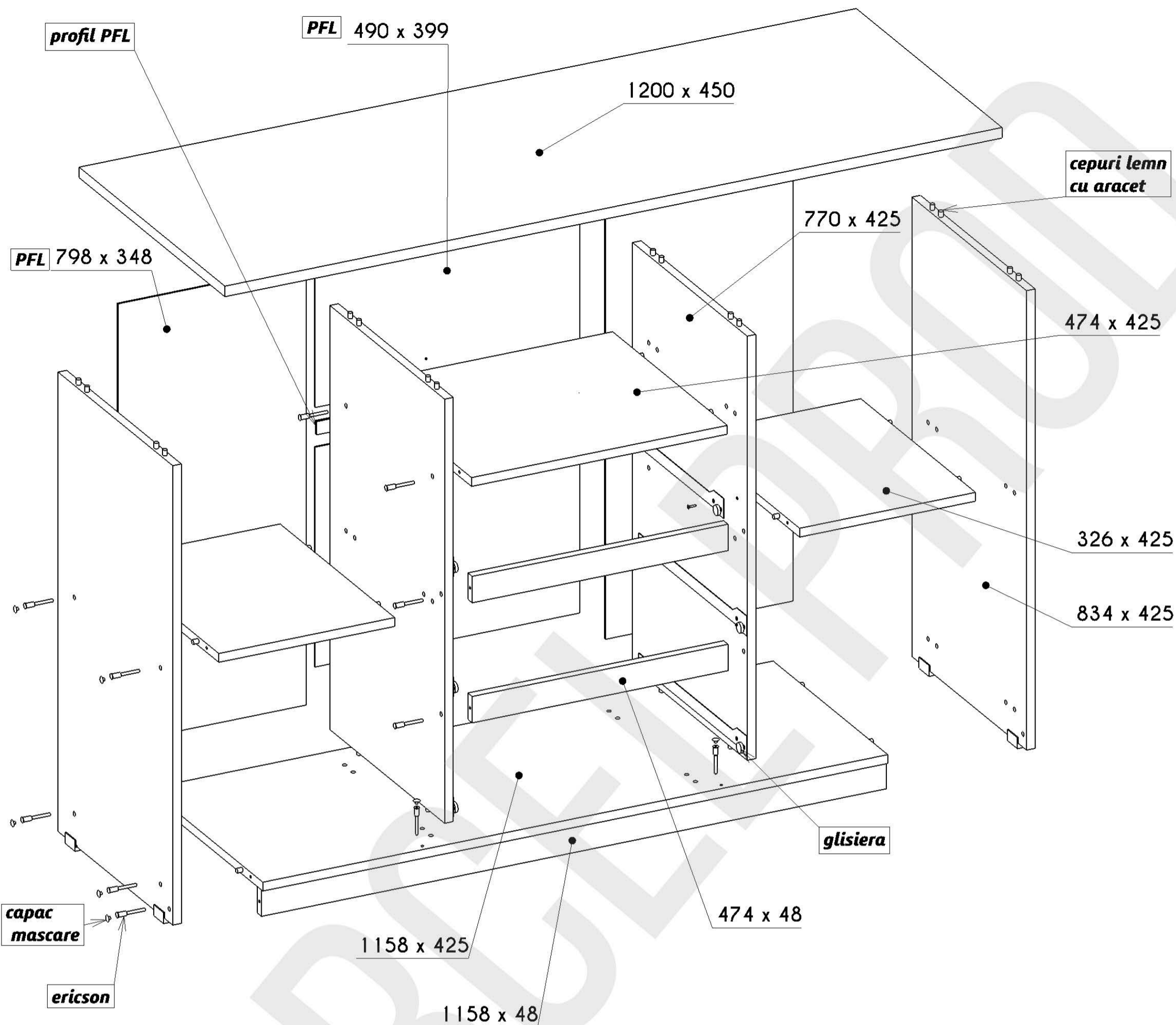

## DETALII MONTAJ

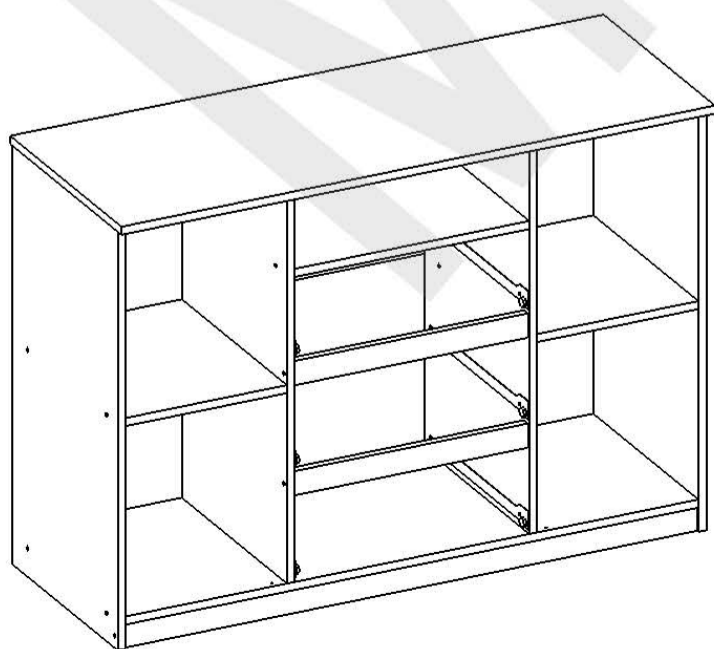

- se pune aracet in partea de sus a peretilor si se bat cepurile cu atentie
- se bat cep-urile din lemn in polite si in partea de jos a peretilor intermediari
- se prind glisierile de peretii laterali cu holzs. 3.5x16 cu rola spre partea cantuita
- se prind picioarele ( in cantul peretilor laterali ) la 40mm fata de margine. ( se folosesc holzsuruburi 3.5x25)
- se aseaza peretele intermediar stanga ( 770x425 ) cu partea cantuita in jos, se prind cele politele si cele 2 lezene ( cu ericsoane si cheie imbus )
- se prinde peretele intermediar dreapta si polita mare ( 1158x425 )
- se prinde lezena mare ( 1158x48 ) si cei 2 pereti laterali
- se ridica corpul pe picioare, se pune aracet in gaurile din capac si se va fixa in peretii laterali ( va fi aliniat la spate )
- se lasa 5 min. pana se intareste aracetul
- se aseaza comoda cu partea cantuita in jos, se impinge in colturi pana cand cele 2 diagonale sunt egale
- se bate PFL-ul in tinte ( dist. intre tinte este de 100mm )

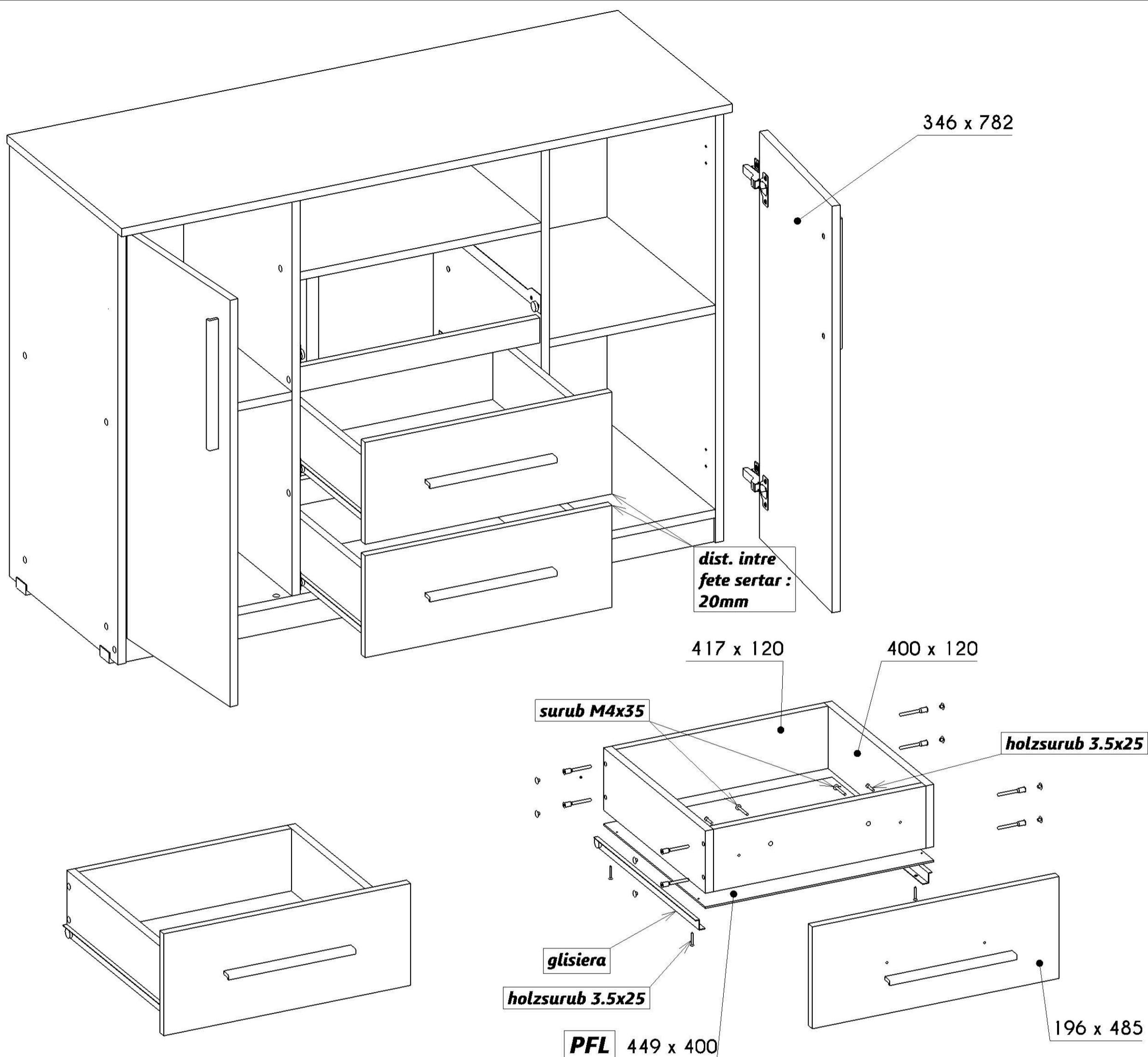

**DETALII MONTAJ**

- se prind balamalele pe usi cu holzsuruburi 3.5x16mm
- se prind usile pe corp ( se lasa 2 mm fata de capac )
- se vor monta sertarele cu ericsoane, se vor masura diagonalele ( se impinge in colturi pana sunt egale ) si se prinde PFL-ul in tinte.
- se prind glisierele ( cu rola spre spate ) cu holzsuruburi 3.5x25
- se prind fetele de sertar cu suruburi M4x35 si manere
- se aseaza pe glisierele din corp, se regleaza luft
- se scot sertarele pe rand, cu atentie si se vor insuruba cate 2 holzsuruburi 3.5x25 ( pentru fixare ).

